

inoxtruck

ELECTRO MANUAL STACKER MINI-LOAD

- Hygienic innovative design
- Aggressive environments resistant chassis
- Electric lifting
- Extremely light

The electromanual stackers manufactured by ULMA Inoxtruck have been designed to rolls, boxes and implements handling in manufacturing clean rooms.

The electric lifting system minimize the manual handling of load and maintain the load in an ergonomic height to handle it, reducing efforts.



Hygienic Innovative Design

Totally opened chassis, continuous weldings, protected lifting cable and his tubular structure make possible a daily equipment cleaning without affecting his features, avoiding rusting problems thanks to stainless steel, plastic and polymer materials that they use.

Maximum Safety

The drive wheels with brakes make the loading and unloading of rolls, implements... a safe operation. Furthermore, the 2 rollers of the structure helps to get out any object between supporting tube and roller. The 2 sensors installed in the structure make possible an automatic stop when the carriage achieve his upper and lower limit .

Robust, Durable and Easy Handling Structure

The 2 ergonomic handles and the electric lifting/descent button allows an easy handling of the stacker.

Front and Side Handling

The lifting system of the different tailor-made designed implements, make possible the front/side replacement of rolls, boxes and implements.

Characteristics			
1.1	Manufacturer (Abreviation)		ULMA Inoxtruck
1.2	Manufacturer's model designation		EMS200
1.3	Power source: battery, diesel, LP gas, petrol		Battery
1.4	Operator type: manual, pedestrian, operator standing, seated		Pedestrian
1.5	Load capacity	Q	200
1.6	Load center distance	c	425
1.8	Chassis		AISI 304L
1.9	Sheet		AISI 304L
Weight			
2.1	Truck weight with nominal load & maximum battery weight		350
2.2	Axle loading nominal load & maximum battery weight, drive/load side		35/65
2.3	Axle loading without load & maximum battery weight, drive/load side		160/190
Dimensions			
3.1	Tyres: P=Polyurethane, PA=Polyamide (nylon), Vul=Vulkollan, drive/load side		P/P
3.2	Tyre dimensions, drive side		125 X 32
3.3	Tyre dimensions, load side		80 X 24
3.5	Number of wheels, drive/load side, (x=driven)		2/2
3.6	Track width (center of tyres), drive side	b10	480
3.7	Track width (center of tyres), load side	b11	480
Dimensions			
4.2	Height with mast lowered	h1	1995
4.4	Lift height	h3	1415
4.5	Overall height with mast raised	h4	1995
4.15a	Fork height, fully lowered	h13	140
4.15b	Fork height, fully extended	h12	1550
4.19	Overall length	l1	1015
4.20	Length to fork face (includes fork thickness)	l	375
4.21	Overall width	b1/b2	580
4.25	Outside width over forks (minimum/maximum)	b5	545
4.32	Ground clearance at center of wheelbase (forks lowered)	m2	30
4.34a	Working aisle width (Ast) with load	Ast	1250
4.35	Turning circle radius	Wa	1005
Performance			
5.2	Lifting speed with/without load	m/s	0.075/0.1
5.3	Lowering speed with/without load	m/s	0.1/0.1
Electric Motor			
6.2	Lift motor output at 15% duty factor	kW	0.45
6.4	Battery voltage/capacity at 5 hour discharge	V/Ah	24/22
6.5	Battery weight	kg	2x20

ULMA Inoxtruck's products are constantly improving. Because of this reason, some materials, options and specifications can be changed without previous notification.

Options

- Implements for handling: rolls, cast, boxes, etc.

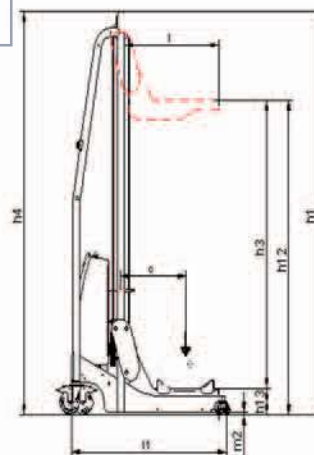
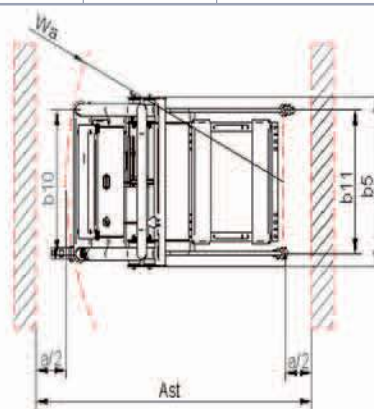

USEMS250AENGI1113



ULMA Inoxtruck • Garagaltza auzoa, 51 • 20560 Oñati (Gipuzkoa)

Tel: 902 702 919

info@ulmainoxtruck.com • www.ulmainoxtruck.com