

CX35 AdvancedLine

Checkweighing and X-ray Combination



Precision and versatility: CX35 AdvancedLine – the industry's most compact all-in-one inline solution for up to 10 kg products, combining fast weight data capture and reliable detection of foreign bodies. The CX35 AdvancedLine offers highly accurate weighing and checks products for contaminants, protecting your consumers and the reputation of your brand.

Where production line space is precious, replacement or retrofiting is very easy thanks to the extremely short CX35 AdvancedLine footprint. With its shortest overall length at 1800 mm, this system is extraordinarily space saving for integration in existing product lines. It performs both true weight measurement thanks to the MID approved checkweigher, and market leading x-ray detection sensitivity.

The x-ray system can detect contaminants such as metal, glass, calcified bone, mineral stone, high-density plastics and rubbers. Minimum training is required to set up menus – ensuring minimal downtime.

This innovative system excels in flawless product handling and performs a dual function that meets quality assurance criteria in accordance with IFS or FDA 21 CFR part 11.

Maximum Safety in Minimal Spaces

In-line Weighing and Contaminant Detection

CX35 AdvancedLine unites the best from two technologies **with only four feet on the floor:**



Increased Line Efficiency

Excelling in throughput with up to 300 packs per minute, this combination system helps to increase productivity and efficiency. The large touchscreens and multi-lingual software reduce the risk of operator errors and save time. Should the checkweigher operating terminal ever fail, the system will still function and can still be used as a critical control point (CCP).



Double Protection of Your Brand

Within this single unit, with full local weighing standards approval and MID certifiable, the checkweigher ensures reliable rejection of either incorrect weight or contaminated products – performing true weight measurement. With its advanced x-ray generator, detector and software the x-ray system achieves outstanding detection results to avoid costly product recalls.



Hygiene-friendly Design

Hygienic condition is supported by the open design frame, curved surfaces and refined materials which reduce adhesion of dirt and ensure easier cleaning. Easy access to all machine areas with no hidden bug traps facilitates cleaning, supports HACCP and HARPC regimes and helps ensure maximum uptime.



Customized Product Handling

Customizable with up to 180 performance and productivity enhancing options. Product handling variants include sidegrip conveyors and top and bottom conveyors to ensure smooth product flow – even through the curtains of the x-ray unit.



Global Services

To reach full compliance and target performance levels from day one, METTLER TOLEDO offers a range of global services. These include a professional start-up service of your device, 24 month full coverage of labor and parts, user training and recommended spare part kits.



5 Year X-ray Generator Warranty

All METTLER TOLEDO x-ray systems come with a five-year generator warranty with the purchase of a standard or comprehensive service contract. By protecting the most valuable part of your x-ray system, you can have confidence that production uptime is safeguarded.

X-ray Inspection Systems to Optimally Suit Application and Product

X33 Model

Designed for ease-of-use, the X33 offers high detection capabilities, safeguarding brands and consumers, while its low energy consumption reduces the Total Cost of Ownership. The X33 is a compact, easy-to-use, high level detection x-ray solution for small to medium sized food packs on single lanes. X33 x-ray systems are suitable for various packaged products such as foil and plastic containers, cartons, bags and pouches.



X33



X34

X34 Model

The X34 is designed to deliver a new level of brand protection for small and medium sized food packs on single lanes at high throughputs. The X34 offers automated product set-up coupled with intelligent software to improve production uptime, reduce manufacturing costs and enhance detection sensitivity, providing the ultimate in product safety with minimum False Reject Rate (FRR).

Unique benefits and features of the X34 are:

- Outstanding detection sensitivity due to an Optimum Power Generator and 0.4 mm detector
- Reliable brand protection due to advanced, class-leading x-ray software ContamPlus™
- Maximum uptime and ease-of-use due to fully automated product set-up capabilities
- Reduced product waste due to minimum FRR (false rejects rates)
- Confidence in performance and reliability due to our unique five-year generator warranty

The Most Essential Options at a Glance An Extract from the Large Range

Options and Accessories – Mechanical/Electromechanical

- High-performance conveyors or high-precision conveyors for maximum weighing accuracy
- Water protection design (IP65, stainless steel conveyors with easy belt removal)
- Up to six additional infeed conveyors for timing and spacing
- Sidegrip or top-bottom conveyors for flawless product transfer
- Various sorting/rejecting devices such as pusher/air jet with smart bin, swing gate, lift gate, lift-up conveyor, drop-down conveyor
- Product collection devices such as stainless steel catch bins, turntable, and gravity roller path

- Checkweigher's HMI or enclosure mounted separately for optimal usability
- Various shields and safeguards for enhanced weighing performance as well as high process safety

Options and Accessories – Electronic/Software

- Extensive statistical functions and printing/output options
- Automatic filling process readjustment (feedback control with eight individual controllers for fill heads), standard or extended version
- Several sensors to identify askew packages or open packages – to ensure high product quality

- Extensive monitoring and alarm options e.g. back-up detection and successive errors detection as well as color-coded and/or acoustic signaling devices to allow immediate reaction to production line problems
- Data interfaces and protocols e.g. Fieldbus (DeviceNet, PROFINET, PROFIBUS), OPC DA and UA, RS232/422/485, CL20 active/passive, industrial Ethernet/IP
- Interface to the METTLER TOLEDO SQC system FreeWeigh.Net™ or ProdX™ data management system – for remote access and enhanced insight in production processes
- Control panel (control enclosure) with UL approval available on request

– Many other options and accessories available –

CX35 AdvancedLine Checkweighing and X-ray Inspection Combination

– Precision and Versatility

General Technical Data

Approval (DE)	DE-17-MI006-PTB006 Weights & Measures design approval for official verification (MID certifiable)
Weighing technology	Electromagnetic force restoration (EMFR) load cell, digital, maintenance-free, with temperature compensation, Swiss made
Weighing terminal (HMI)	15-inch color touchscreen TFT display, with emergency stop button, individual user access profiles with password protection, more than 30 selectable languages for the dialog/prompts; display of all key up-to-date weight data, production and configuration screens; real-time data capture and distribution
Conveyor belt speed	Continuously variable
X-ray beams	Single beam
X-ray protection	Fully contained emissions within construction
X-ray emissions	< 1 uSv/hr

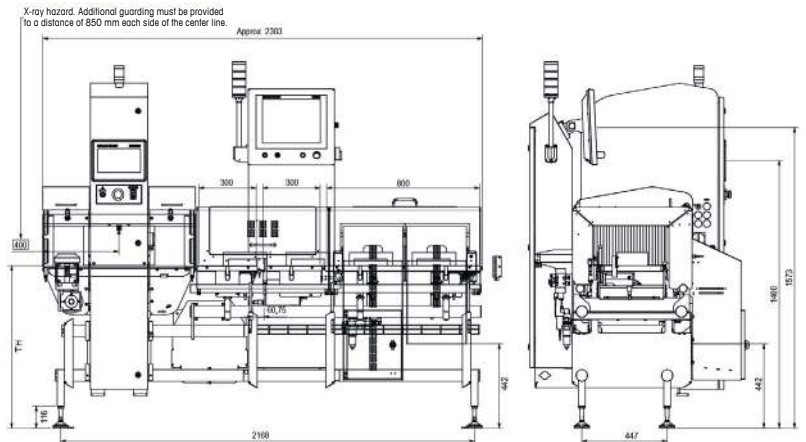

Typical dimensions in mm (A-A, B-B vary depending on conveyor size); the front view shows product transport direction left-to-right version

Technical Details

CX35 AdvancedLine

Weighing range*	3 g - 10000 g
Accuracy**	from ± 0.01 g (10 mg)
Classification	in 3, 5 or 7 weight zones
Zero reset	automatic or manual
Throughput	300 products per minute
Max. product height	with X33: 200 mm or 240 mm; with X34: 200 mm
X-ray detector	300 or 400 mm scan width, X33: 0.8 mm diode size; X34: 0.4 or 0.8 mm diode size
X-ray generator	with X33: 20 W, 84 kV, 0.25 mA glass or optional Beryllium tube; with X34: Optimum Power 100 W, up to 84 kV, up to 3.3 mA glass or optional Beryllium tube
X-ray system display	with X33: 10.1" LED touchscreen display (16:9 aspect ratio); with X34: 10.1" PCAP capacitive touchscreen display (16:9 aspect ratio)
Infeed conveyor length (A-A) range	250 - 600 mm (distance between roller centers)
Infeed conveyor width (B-B) range	150 - 300 mm
Weighing conveyor length (A-A) range	250 - 600 mm (distance between roller centers)
Weighing conveyor width (B-B) range	150 - 300 mm
Outfeed conveyor length (A-A) range	250 - 1800 mm (distance between roller centers)
Outfeed conveyor width (B-B) range	150 - 300 mm
Line height (TH), other heights on enquiry	750 - 1100 mm (± 50 mm)
Compressed air supply	approx. 6 bars (87 p.s.i.)
Noise level, standard system at full speed***	less than 70 dBA at 1 m height and 1 m distance
Electrical (with lockable mains disconnect)	110/230 VAC, single-phase, 50/60 Hz, 750 VA - 1 kVA
Ingress protection rating	IP 54, optional IP 65 (water protection design)
Surface finish	stainless steel, glass bead blasted/finely sanded (grit 240)

* depending on product weight and the design and dimensions of the weighing conveyor used; max. load may be restricted by product suitability for x-raying depending on size and density

** within the approved tolerances, depending on the weight, dimensions and transport behaviour of the product being weighed

*** certain conveyor and sorting/rejecting device options may increase the system noise level

Multi-lane applications and combinations with METTLER TOLEDO Safeline X-ray systems other than X33 and X34 e.g. X36 are available on request.



Mettler-Toledo Group

Product Inspection Division

Local contact: www.mt.com/contacts

www.mt.com/pi-integrated-solutions

For more information

Subject to technical changes. Images are examples only.

© 05/2019 METTLER TOLEDO. All rights reserved.

227 EN